

Owner's Manual

GUITAR AMPLIFIER

JAZZ CHORUS

JC-22

English

日本語

Deutsch

Français

Italiano

Español

Português

Nederlands

Main Features

The JC-22 is a 30 W stereo-input/output guitar amp featuring a transparently clean tone that faithfully expresses the true character of your guitar.

- Its unique stereo-input design lets you connect a stereo effect unit to the front panel and enjoy a stereo effect using just a single amp.
- A beautifully dimensional space chorus effect is produced by spatial mixing (allowing the direct sound and effect sound to mix in the air).
- In addition to a 3-band tone-stack EQ, it also provides a bright switch, giving you a rich palette of tone settings.
- With two independent power amps and two custom-designed 6.5-inch speakers, the JC-22 delivers a stereo effect.
- The enclosure is designed for strength and durability, made of hardened fiberboard and equipped with corner protectors.
- If a separately sold footswitch is connected, you can turn chorus and reverb on/off with your foot.

Dimensional space chorus

This uses two completely independent amps and speakers; one amp and speaker output the direct sound that is sent from the guitar, while the other amp and speaker output a sound that is subtly pitch-modulated. These two sounds are mixed in the air, creating a softly spacious three-dimensional effect that is warm, deep, and natural-sounding.

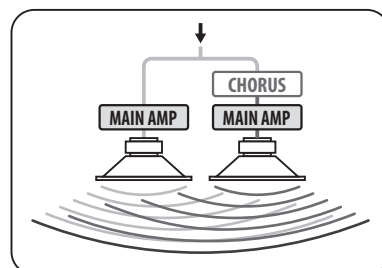

USING THE UNIT SAFELY

Before using this unit, carefully read "IMPORTANT SAFETY INSTRUCTIONS" (inside front cover), "USING THE UNIT SAFELY" (p. 2), and "IMPORTANT NOTES" (p. 3). After reading, keep the document(s) including those sections where it will be available for immediate reference.
Copyright © 2016 ROLAND CORPORATION

INSTRUCTIONS FOR THE PREVENTION OF FIRE, ELECTRIC SHOCK, OR INJURY TO PERSONS

About ⚠ WARNING and ⚠ CAUTION Notices

⚠ WARNING	Used for instructions intended to alert the user to the risk of death or severe injury should the unit be used improperly.
⚠ CAUTION	Used for instructions intended to alert the user to the risk of injury or material damage should the unit be used improperly. * Material damage refers to damage or other adverse effects caused with respect to the home and all its furnishings, as well to domestic animals or pets.

About the Symbols

	The ⚠ symbol alerts the user to important instructions or warnings. The specific meaning of the symbol is determined by the design contained within the triangle. In the case of the symbol at left, it is used for general cautions, warnings, or alerts to danger.
	The symbol alerts the user to items that must never be carried out (are forbidden). The specific thing that must not be done is indicated by the design contained within the circle. In the case of the symbol at left, it means that the unit must never be disassembled.
	The symbol alerts the user to things that must be carried out. The specific thing that must be done is indicated by the design contained within the circle. In the case of the symbol at left, it means that the power-cord plug must be unplugged from the outlet.

ALWAYS OBSERVE THE FOLLOWING

WARNING

Make sure that the power cord is grounded

Connect mains plug of this model to a mains socket outlet with a protective earthing connection.



To completely turn off power to the unit, pull out the plug from the outlet

Even with the power switch turned off, this unit is not completely separated from its main source of power. When the power needs to be completely turned off, turn off the power switch on the unit, then pull out the plug from the outlet. For this reason, the outlet into which you choose to connect the power cord's plug should be one that is within easy reach and readily accessible.



Secure a sufficient amount of space at the setup location

Since this unit normally emits a slight amount of heat, make sure to secure sufficient space around it, as shown below.

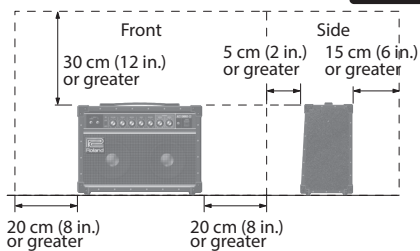

Do not disassemble or modify by yourself

Do not carry out anything unless you are instructed to do so in the owner's manual. Otherwise, you risk causing malfunction.



Do not repair or replace parts by yourself

Refer all servicing to your retailer, the nearest Roland Service Center, or an authorized Roland distributor, as listed on the "Information."



WARNING

Do not use or store in the following types of locations

- Subject to temperature extremes (e.g., direct sunlight in an enclosed vehicle, near a heating duct, on top of heat-generating equipment); or are
- Damp (e.g., baths, washrooms, on wet floors); or are
- Exposed to steam or smoke; or are
- Subject to salt exposure; or are
- Exposed to rain; or are
- Dusty or sandy; or are
- Subject to high levels of vibration and shakiness; or are
- Placed in a poorly ventilated location.



Do not place in an unstable location

Otherwise, you risk injury as the result of the unit toppling over or dropping down.



Connect the power cord to an outlet of the correct voltage

The unit should be connected to a power supply only of the type described as marked on the rear side of unit.



Use only the supplied power cord

Use only the attached power cord. Also, the supplied power cord must not be used with any other device.



Do not bend the power cord or place heavy objects on it

Otherwise, fire or electric shock may result.



Avoid extended use at high volume

Use of the unit at high volume for extended periods of time may cause hearing loss. If you ever experience any hearing loss or ringing in the ears, you should immediately stop using the unit and consult a specialized physician.



WARNING

Do not allow foreign objects or liquids to enter unit; never place containers with liquid on unit

Do not place containers containing liquid (e.g., flower vases) on this product. Never allow foreign objects (e.g., flammable objects, coins, wires) or liquids (e.g., water or juice) to enter this product. Doing so may cause short circuits, faulty operation, or other malfunctions.



Turn off the unit if an abnormality or malfunction occurs

Immediately turn the unit off, remove the power cord from the outlet, and request servicing by your retailer, the nearest Roland Service Center, or an authorized Roland distributor, as listed on the "Information" when:



- The power cord has been damaged; or
- If smoke or unusual odor occurs; or
- Objects have fallen into, or liquid has been spilled onto the unit; or
- The unit has been exposed to rain (or otherwise has become wet); or
- The unit does not appear to operate normally or exhibits a marked change in performance.

Be cautious to protect children from injury

Always make sure that an adult is on hand to provide supervision and guidance when using the unit in places where children are present, or when a child will be using the unit.



Do not drop or subject to strong impact

Otherwise, you risk causing damage or malfunction.



Do not share an outlet with an unreasonable number of other devices

Otherwise, you risk overheating or fire.



Do not use overseas

Before using the unit in overseas, consult with your retailer, the nearest Roland Service Center, or an authorized Roland distributor, as listed on the "Information."



The ventilation should not be impeded by covering the ventilation openings with items such as newspaper, table-cloths, curtains etc.



No naked flame sources such as lighted candles should be placed on the apparatus.



Use the apparatus in moderate climates.



⚠ CAUTION

When disconnecting the power cord, grasp it by the plug

To prevent conductor damage, always grasp the power cord by its plug when disconnecting it.



Periodically clean the power plug

An accumulation of dust or foreign objects between the power plug and the power outlet can lead to fire or electric shock.



At regular intervals, be sure to pull out the power plug, and using a dry cloth, wipe away any dust or foreign objects that may have accumulated.

Disconnect the power plug whenever the unit will not be used for an extended period of time

Fire may result in the unlikely event that a breakdown occurs.



⚠ CAUTION

Route all power cords and cables in such a way as to prevent them from getting entangled

Injury could result if someone were to trip on a cable and cause the unit to fall or topple.



Avoid climbing on top of the unit, or placing heavy objects on it

Otherwise, you risk injury as the result of the unit toppling over or dropping down.



Never connect/disconnect a power plug if your hands are wet

Otherwise, you could receive an electric shock.



Disconnect all cords/cables before moving the unit

Before moving the unit, disconnect the power plug from the outlet, and pull out all cords from external devices.



⚠ CAUTION

Before cleaning the unit, disconnect the power plug from the outlet

If the power plug is not removed from the outlet, you risk receiving an electric shock.



Whenever there is a threat of lightning, disconnect the power plug from the outlet

If the power plug is not removed from the outlet, you risk causing malfunction or receiving an electric shock.



English

日本語

Deutsch

Français

Italiano

Español

Português

Nederlands

IMPORTANT NOTES

Power Supply

- Do not connect this unit to same electrical outlet that is being used by an electrical appliance that is controlled by an inverter or a motor (such as a refrigerator, washing machine, microwave oven, or air conditioner). Depending on the way in which the electrical appliance is used, power supply noise may cause this unit to malfunction or may produce audible noise. If it is not practical to use a separate electrical outlet, connect a power supply noise filter between this unit and the electrical outlet.

Placement

- Using the unit near power amplifiers (or other equipment containing large power transformers) may induce hum. To alleviate the problem, change the orientation of this unit; or move it farther away from the source of interference.
- This unit may interfere with radio and television reception. Do not use this unit in the vicinity of such receivers.
- Noise may be produced if wireless communications devices, such as cell phones, are operated in the vicinity of this unit. Such noise could occur when receiving or initiating a call, or while conversing. Should you experience such problems, you should relocate such wireless devices so they are at a greater distance from this unit, or switch them off.
- When moved from one location to another where the temperature and/or humidity is very different, water droplets (condensation) may form inside the unit. Damage or malfunction may result if you attempt to use the unit in this condition. Therefore, before using the unit, you must allow it to stand for several hours, until the condensation has completely evaporated.
- Depending on the material and temperature of the surface on which you place the unit, its rubber feet may discolor or mar the surface.
- Do not place containers or anything else containing liquid on top of this unit. Also, whenever any liquid has been spilled on the surface of this unit, be sure to promptly wipe it away using a soft, dry cloth.

Maintenance

- Never use benzine, thinners, alcohol or solvents of any kind, to avoid the possibility of discoloration and/or deformation.

Additional Precautions

- Use a reasonable amount of care when using the unit's buttons, sliders, or other controls; and when using its jacks and connectors. Rough handling can lead to malfunctions.
- When disconnecting all cables, grasp the connector itself—never pull on the cable. This way you will avoid causing shorts, or damage to the cable's internal elements.
- A small amount of heat will radiate from the unit during normal operation.
- To avoid disturbing others nearby, try to keep the unit's volume at reasonable levels.
- Do not use connection cables that contain a built-in resistor.

Intellectual Property Right

- Roland and BOSS are either registered trademarks or trademarks of Roland Corporation in the United States and/or other countries.
- Company names and product names appearing in this document are registered trademarks or trademarks of their respective owners.

Panel Descriptions

Front Panel

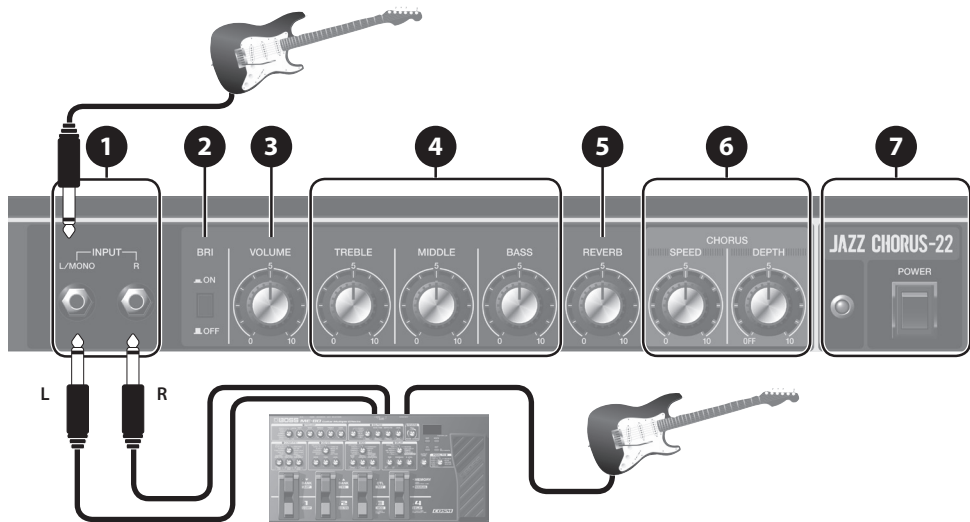

1 INPUT jacks

Connect your electric guitar or effect unit here. If you're connecting a guitar directly, or a monaural effect unit, connect it to the L/ MONO jack. If you connect a stereo-output effect unit to these jacks, you'll obtain a stereo effect with the left and right speakers of the JC-22.

* If you connect your guitar to the R jack, the sound is heard only from the right speaker.

2 [BRI] (Bright) switch

Brightens the mid- and high-frequency range, making the sound more crisp.

3 [VOLUME] knob

Adjusts the overall volume.

4 [TREBLE] / [MIDDLE] / [BASS] knobs

Adjust the volume of the high-, mid-, and low-frequency ranges respectively.

5 [REVERB] knob

Adjusts the reverb depth.

6 CHORUS

The JC-22 features dimensional space chorus effects.

[SPEED] knob

Adjusts the modulation speed of chorus.

[DEPTH] knob

Adjusts the modulation depth of chorus. If this is set to "OFF," chorus is not applied.

7 [POWER] switch

Turns the power of the JC-22 on/off. When the power is on, the indicator is lit.

Turning the Power On/Off

1. Make sure that the JC-22's [VOLUME] knob and the volume of the devices connected to the JC-22 are set to 0.

* Before connecting your instrument to the JC-22's INPUT jacks, set the [VOLUME] knob to the minimum setting (far left).

2. Turn on the JC-22.

* Before turning the unit on/off, always be sure to turn the volume down. Even with the volume turned down, you might hear some sound when switching the unit on/off. However, this is normal and does not indicate a malfunction.

3. Turn on the power of the connected devices.

4. Adjust the volume levels for the devices.

Before switching off the power, lower the volume on each of the devices in your system and then TURN OFF the devices in the reverse order to which they were switched on.

* If you need to turn off the power completely, first turn off the unit, then unplug the power cord from the power outlet. Refer to "To completely turn off power to the unit, pull out the plug from the outlet" (p. 2).

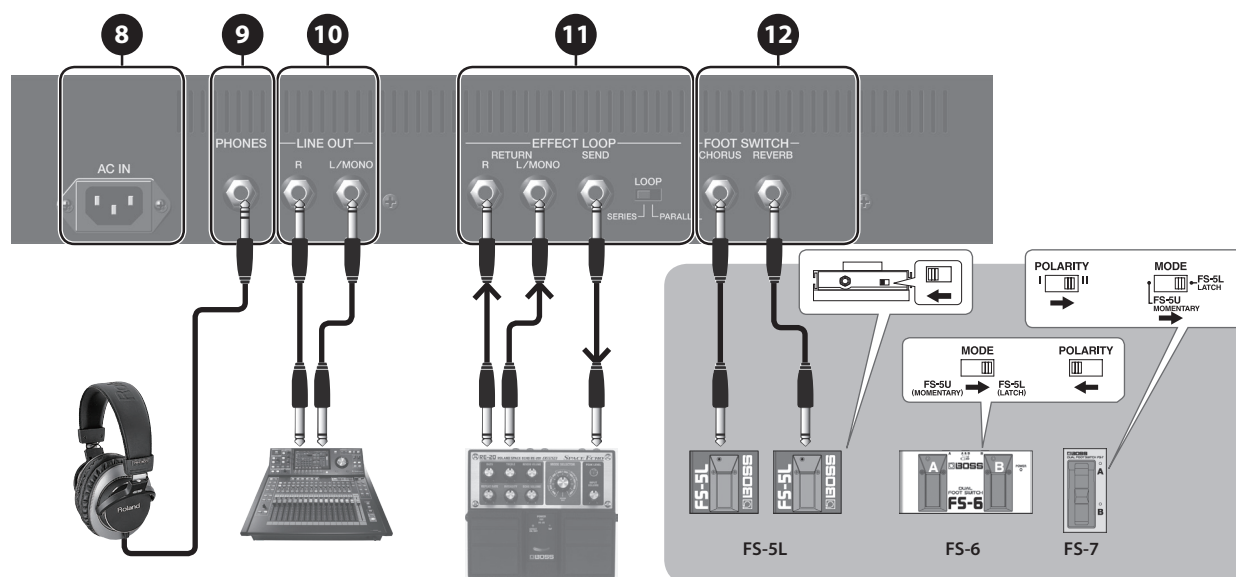

Rear Panel

**8 AC IN jack**

Connect the included power cord.

- * Use only the power cord that was included with the unit.

9 PHONES jack

Connect headphones here.

- * If a plug is inserted in this jack, no sound will be output from the JC-22's own speaker.

10 LINE OUT jacks

Connect these to your PA system or recorder.

You can use this in conjunction with an external PA system, or to record your performance via direct line while monitoring the sound from the JC-22's speaker.

If you're using a monaural connection, connect your equipment to the L/MONO jack.

- * If chorus is on and you connect the line out in stereo, the dimensional space chorus effect (L: direct sound, R: effect sound) is obtained.

11 EFFECT LOOP SEND/RETURN jacks

Connect an external effect device.

Connect the SEND jack to the input of your external effect device, and connect the output of your external effect device to the RETURN jack.

If you connect a stereo effect unit, the stereo effect is obtained using the JC-22's left and right speakers. If you're connecting a monaural effect unit, connect it to the L/MONO jack.

- * If you connect only the R jack, sound is not output from the speakers, the LINE OUT jacks, and the PHONES jack.
- * The sound that is input from the RETURN jacks is not affected by front panel controls **2-4**. If you want controls **2-4** to affect this sound, connect your equipment to the front panel INPUT (L/MONO, R) jacks.
- * To prevent malfunction and equipment failure, always turn down the volume, and turn off all the units before making any connections.

[LOOP] switch

When "PARALLEL" is set, the external effects sound and the direct sound are mixed.

When "SERIES" is set, only the external effects sound is played.

- * When "SERIES" is set, there will be no sound if the volume of your external effect device is turned down or if it is powered-off.
- ➔ For details on the EFFECT LOOP SEND/RETURN jacks and the [LOOP] switch, refer to "Block Diagram" at the end of this manual.

12 FOOT SWITCH jacks

If a separately sold footswitch (BOSS FS-5L, FS-6, FS-7) is connected, you can turn chorus and reverb on/off with your foot.

- * The JC-22 is compatible with latch-type footswitches (FS-5L, FS-6, FS-7). If you're using an FS-6 or FS-7, set the mode of A and B to FS-5L (LATCH).
- * If you're using an FS-6 or FS-7, connect a 1/4" plug (monaural) to jack A or B.
- * If you're using the A&B jack of the FS-6, use a stereo 1/4" plug ↔ two 1/4" monaural plugs (sold separately: PCS-31L, etc.).

Block Diagram

JC-22 Block Diagram

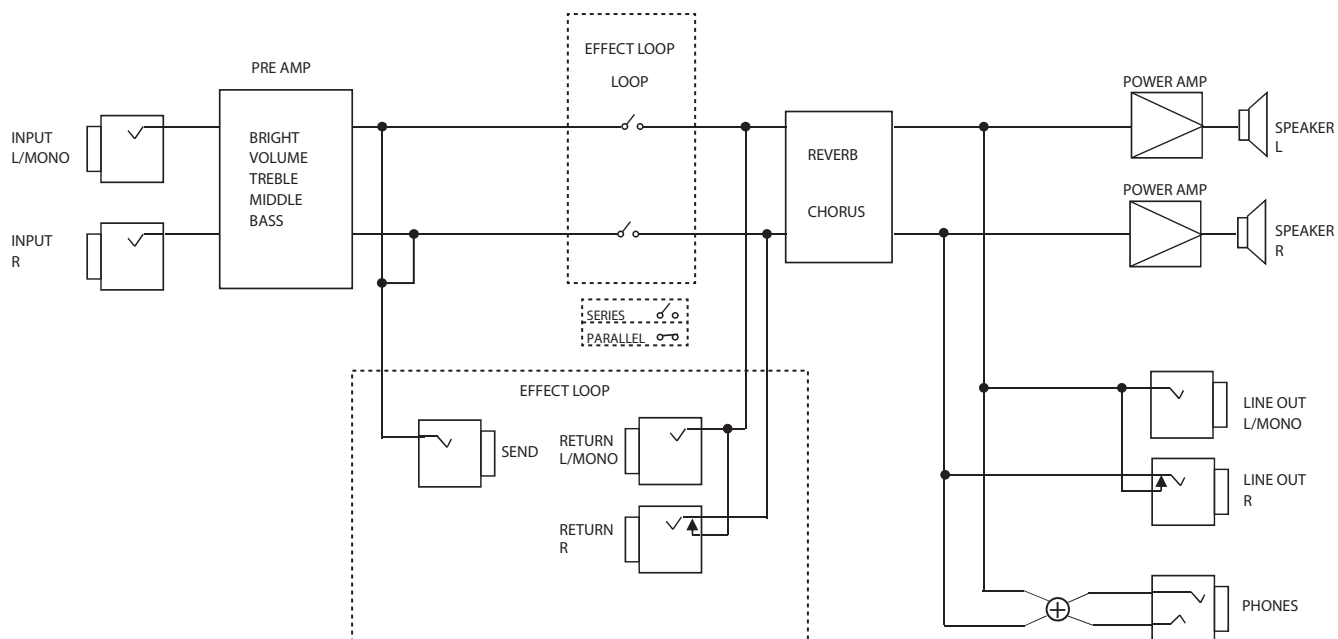

EFFECT LOOP (series)

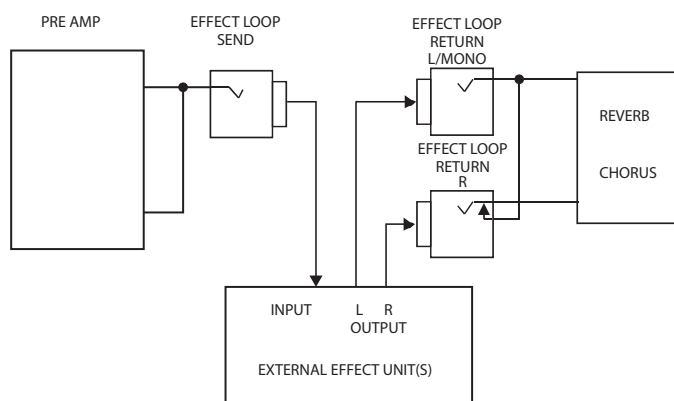

EFFECT LOOP (parallel)

