

NOTE

- When setting-up or adjusting the stand, take care not to pinch your fingers between movable parts and the main unit. If using this in a location where children are present, be sure to provide adult supervision or guidance.
- Prepare an area in which you can perform the assembly safely.
- Do not use a power tool (e.g., an electric screwdriver) to assemble the stand. You risk damaging or stripping the screws.
- When removing the parts from the packing carton, take care that your box cutter or other sharp implement does not scratch the pipes.
- If you will be using this drum stand for an extended period of time in the same location, we recommend that you use a drum mat (TDM series) made by Roland to prevent the rubber feet from soiling the surface on which they are placed.



How to Set Up the Stand

1. Check the parts

Before you start assembling the stand, make sure that you have all of the parts.

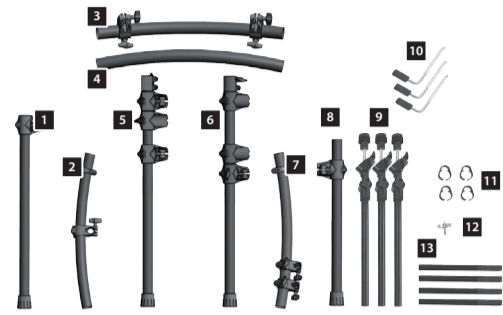

Number	Name	Quantity
1	Straight pipe L (Long)	1
2	Curved pipe L (with one pad mount, with one memory lock)	1
3	Center pipe (upper) (with two pad mounts)	1
4	Center pipe (lower)	1
5	Main unit pipe L (second holder higher)	1
6	Main unit pipe R (second holder lower)	1
7	Curved pipe R (with two pad mounts, with one memory lock)	1
8	Straight pipe R (Short)	1
9	Cymbal mount	3
10	Pad mount	3
11	Cable clip	4
12	Drum key	1
13	Cable tie	4

Aligning the position of pipes and holders

Align the guide hole with the gap of the holder

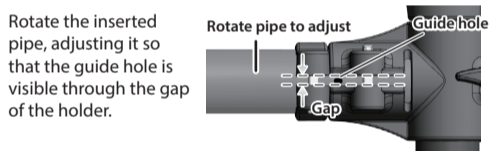

5. Assembling the cymbal mount

5-1. Loosen the hand knob and pull out the rod.

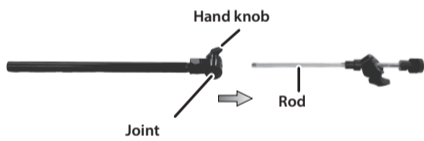

5-2. Rotate the joint and insert the rod.

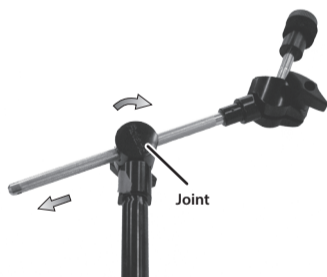

5-3. Tighten the hand knob.

6. Attaching the pad mounts and cymbal mounts

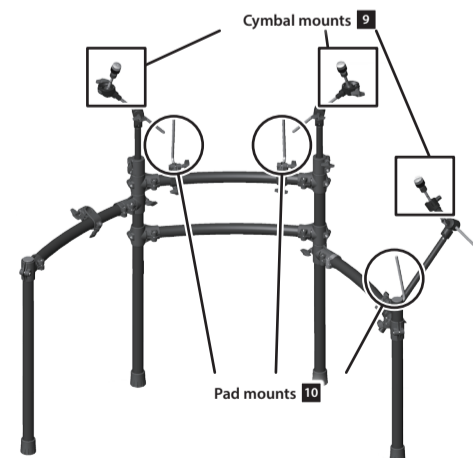

6-2. Attach pad mounts 10 to the holders that you raised, and tighten using the hand knobs (three locations).

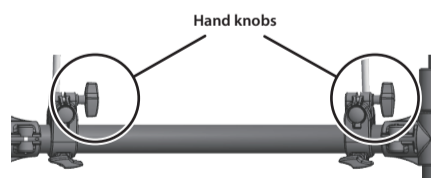

6-3. Attach the cymbal mounts 9 in the positions shown in the illustration, and tighten using the hand knobs (three locations).

Notes

- When setting up or storing the stand, be careful not to pinch the fingers you use to handle the stand.
- Regarding the way of mounting a drum sound module, pads, or cymbals, please refer to the setup guide of your drum kit.

6-1. Raise the mount holders (three locations) of the center pipe (upper) 3 and the curve pipe R 7.

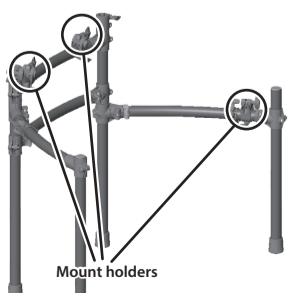

Use the cable clips 11 and cable ties 13 to manage the cables neatly when attaching the pads and the sound module.

2. Assembling the center section

2-1. Attach the center pipes (upper 3/lower 4) to the main unit pipe L 5.

- Insert the center pipe (upper) 3 into the top holder of the main unit pipe L 5.
- Insert the center pipe (lower) 4 into the third holder from the top.

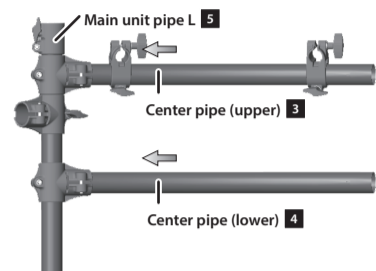

Align the guide hole with the gap of the holder, and tighten (two locations) using the drum key 12.

2-2. Attach the main pipe R 6.

- Insert the center pipe (upper) 3 into the top holder of the main unit pipe R 6.
- Insert the center pipe (lower) 4 into the second holder.

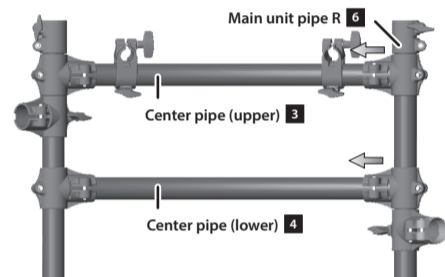

Align the guide hole with the gap of the holder, and tighten (two locations) using the drum key 12.

3. Attaching the left arm section

3-1. Position the second holder from the top of the main unit pipe L 5 facing outward, and insert the curved pipe L 2.

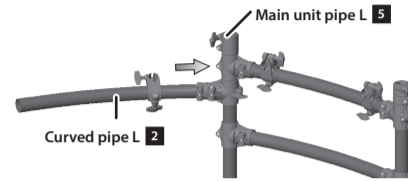

Align the guide hole with the gap of the holder, and tighten using the drum key 12.

3-2. Align the memory lock with the holder, and tighten using the drum key 12.

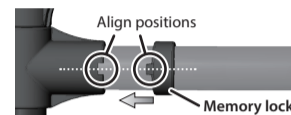

3-3. Attach the straight pipe L 1.

Align the guide hole with the gap of the holder, and tighten using the drum key 12.

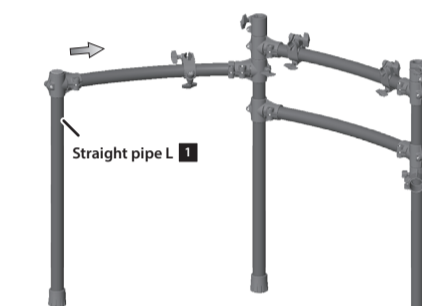

4. Attaching the right arm section

4-1. Position the bottom holder of the main unit pipe R 6 facing outward, and insert curved pipe R 7.

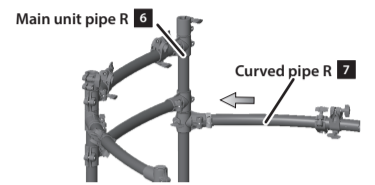

Align the guide hole with the gap of the holder, and tighten using the drum key 12.

4-2. Align the memory lock with the holder, and tighten using the drum key 12.

4-3. Attach the straight pipe R 8.

Align the guide hole with the gap of the holder, and tighten using the drum key 12.

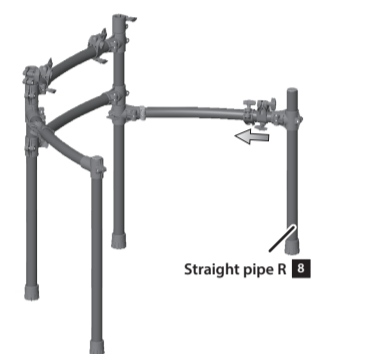

4-4. Verify that the four vertical pipes are truly vertical. If the stand wobbles when placed on the floor, loosen the holders and make adjustments.

When setting up, pay attention to safety so that the stand does not fall over.

Refer to the setup guide of your drum kit, and observe the safety precautions when setting up.

Assembly for a Left-Handed Player

For left-handed use, assemble the stand with left and right reversed as shown in the illustration.

- Before you begin work, loosen the memory locks of curved pipes L 2 and R 7. When you finish assembly, adjust the position and retighten.
- For the position at which to attach each mount, refer to the setup guide of your drum kit.

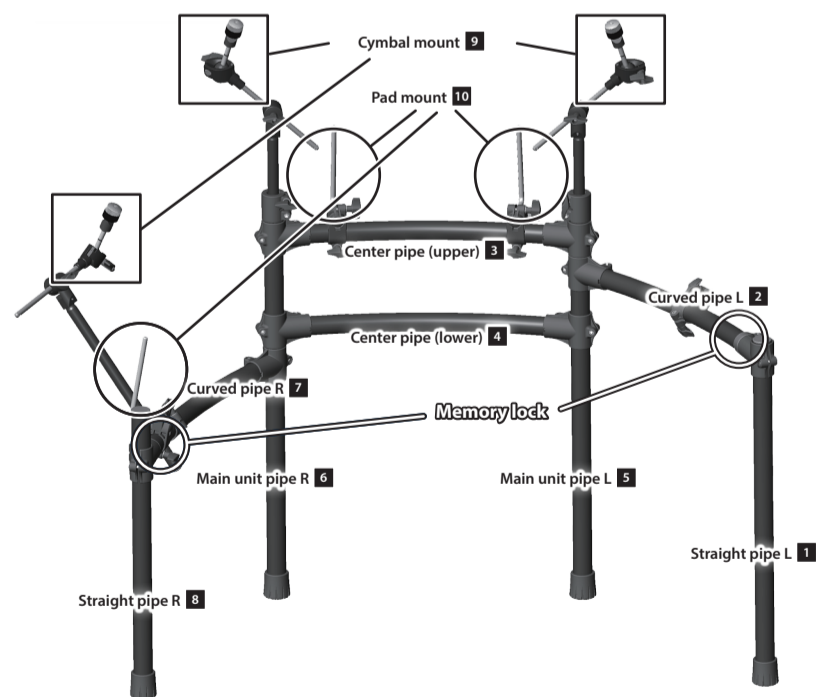

Aligning the position of pipes and holders

1. Turn the inserted pipe to align the guide hole with the holder notch (the mark at which to align the memory lock), and push it all the way in.

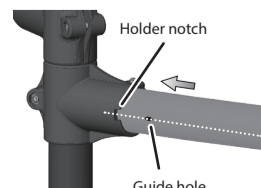

Adjusting the memory lock

1. Use the drum key 12 to loosen the screw of the memory lock.
2. Rotate the memory lock 180 degrees, and align the holder notch with the memory lock mark.

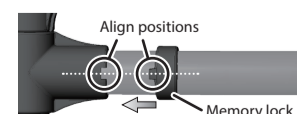

3. Use the drum key 12 to securely tighten the memory lock screw.