

# RC-505mkII LOOP STATION

## Owner's Manual



<b>USING THE UNIT SAFELY</b> .....	<b>2</b>
<b>IMPORTANT NOTES</b> .....	<b>2</b>
<b>How the RC-505mkII Is Organized</b> .....	<b>3</b>
<b>Getting Ready</b> .....	<b>4</b>
Top Panel .....	4
Rear Panel (Connecting Your Equipment) .....	7
Turning the Power On/Off .....	7
Phantom Power Settings .....	7
Switching Between Play Screens .....	8
Adjusting the Input/Output Level .....	8
<b>Creating a Loop Phrase</b> .....	<b>9</b>
Recording on a Single Track.....	9
Recording on Multiple Tracks .....	10
Recording with Input FX.....	11
Record While Listening to the Rhythm Sound .....	11
Sounding a Rhythm .....	11
Setting the Tempo of Rhythm .....	11
<b>Saving a Memory</b> .....	<b>12</b>
Saving a Memory (WRITE) .....	12
Erasing Data from a Memory (CLEAR).....	12
<b>Editing a Memory</b> .....	<b>13</b>
Editing the Settings of a Memory .....	13
Editing the Track Settings .....	14
Editing the Rhythm Settings.....	15
Changing How the Rhythm Starts and Stops.....	15
Editing the Input FX/Track FX Settings.....	16

<b>System Settings (MENU)</b> .....	<b>17</b>
<b>Connecting to a Computer via USB</b> .....	<b>19</b>
Backing Up or Recovering Data .....	19
<b>Controlling Devices via MIDI</b> .....	<b>20</b>
MIDI Settings.....	20
Controlling an External MIDI Device from the RC-505mkII .....	20
Controlling the RC-505mkII from an External MIDI Device .....	21
Connecting Two RC-505mkII Units.....	21
<b>Appendix</b> .....	<b>22</b>
Troubleshooting.....	22
Error Message List .....	23
Restoring the Factory Default Settings (Factory Reset) ....	24
Main Specifications .....	25

**Owner's Manual** (this document)

Read this first. It explains the basic things you need to know in order to use the RC-505mkII.

**Parameter Guide** (download from the Web)

This explains all of the parameters of the RC-505mkII.

**To obtain the Parameter Guide**

1. Enter the following URL on your computer.  
<https://www.boss.info/manuals/>
2. Choose "RC-505mkII" as the product name.



Before using this unit, carefully read "USING THE UNIT SAFELY" and "IMPORTANT NOTES" (the leaflet "USING THE UNIT SAFELY" and the Owner's Manual (p. 2)). After reading, keep the document(s) where it will be available for immediate reference.

# USING THE UNIT SAFELY

## WARNING

### Concerning the Auto Off function

The power to this unit will be turned off automatically after a predetermined amount of time has passed since it was last used for playing music, or its buttons or controls were operated (AUTO OFF function). If you do not want the power to be turned off automatically, disengage the AUTO OFF function (p. 18).



## WARNING

### Use only the supplied AC adaptor and the correct voltage

Be sure to use only the AC adaptor supplied with the unit. Also, make sure the line voltage at the installation matches the input voltage specified on the AC adaptor's body. Other AC adaptors may use a different polarity, or be designed for a different voltage, so their use could result in damage, malfunction, or electric shock.



### Use only the supplied power cord

Use only the attached power cord. Also, the supplied power cord must not be used with any other device.



## CAUTION

### Handle the ground terminal carefully

If you remove the screw from the ground terminal, be sure to replace it; don't leave it lying around where it could accidentally be swallowed by small children. When refastening the screw, make that it is firmly fastened, so it won't come loose.



### Precautions concerning use of phantom power supply

Always turn the phantom power off when connecting any device other than condenser microphones that require phantom power. You risk causing damage if you mistakenly supply phantom power to dynamic microphones, audio playback devices, or other devices that don't require such power. Be sure to check the specifications of any microphone you intend to use by referring to the manual that came with it. (This instrument's phantom power: 48 V DC, 10 mA Max)



# IMPORTANT NOTES

## Power Supply

- Place the AC adaptor so the side with the indicator faces upwards. The indicator will light when you plug the AC adaptor into an AC outlet.
- Depending on the material and temperature of the surface on which you place the unit, its rubber feet may discolor or mar the surface.

## Repairs and Data

- Before sending the unit away for repairs, be sure to make a backup of the data stored within it; or you may prefer to write down the needed information. Although we will do our utmost to preserve the data stored in your unit when we carry out repairs, in some cases, such as when the memory section is physically damaged, restoration of the stored content may be impossible. Roland assumes no liability concerning the restoration of any stored content that has been lost.

## Additional Precautions

- Any data stored within the unit can be lost as the result of equipment failure, incorrect operation, etc. To protect yourself against the irretrievable loss of data, try to make a habit of creating regular backups of the data you've stored in the unit.
- Roland assumes no liability concerning the restoration of any stored content that has been lost.
- Never strike or apply strong pressure to the display.
- When disposing of the packing carton or cushioning material in which this unit was packed, you must observe the waste disposal regulations that apply to your locality.
- Use only the specified expression pedal (FV-500H, FV-500L, EV-30, and Roland EV-5; sold separately). By connecting any other expression pedals, you risk causing malfunction and/or damage to the unit.
- Do not use connection cables that contain a built-in resistor.

## Intellectual Property Right

- It is forbidden by law to make an audio recording, video recording, copy or revision of a third party's copyrighted work (musical work, video work, broadcast, live performance, or other work), whether in whole or in part, and distribute, sell, lease, perform or broadcast it without the permission of the copyright owner.
- Do not use this product for purposes that could infringe on a copyright held by a third party. We assume no responsibility whatsoever with regard to any infringements of third-party copyrights arising through your use of this product.
- The copyright of content in this product (the sound waveform data, style data, accompaniment patterns, phrase data, audio loops and image data) is reserved by Roland Corporation.
- Purchasers of this product are permitted to utilize said content (except song data such as Demo Songs) for the creating, performing, recording and distributing original musical works.
- Purchasers of this product are NOT permitted to extract said content in original or modified form, for the purpose of distributing recorded medium of said content or making them available on a computer network.
- This product contains eParts integrated software platform of eSOL Co., Ltd. eParts is a trademark of eSOL Co., Ltd. in Japan.
- This Product uses the Source Code of  $\mu$ T-Kernel under T-License 2.0 granted by the T-Engine Forum ([www.tron.org](http://www.tron.org)).
- This product includes third party open source software.  
Copyright © 2009-2019 ARM Limited. All rights reserved.  
Licensed under the Apache License, Version 2.0 (the "License");  
You may obtain a copy of the License at  
<http://www.apache.org/licenses/LICENSE-2.0>  
Copyright © 2016, Freescale Semiconductor, Inc.  
Copyright 2016-2019 NXP. All rights reserved.  
Licensed under the BSD-3-Clause;  
You may obtain a copy of the License at  
<https://opensource.org/licenses/BSD-3-Clause>  
Copyright © 2020 Amazon.com, Inc. or its affiliates. All Rights Reserved.  
Licensed under the MIT license  
<https://opensource.org/licenses/mit-license.php>
- Roland, BOSS, and LOOP STATION are either registered trademarks or trademarks of Roland Corporation in the United States and/or other countries.
- Company names and product names appearing in this document are registered trademarks or trademarks of their respective owners.

# How the RC-505mkII Is Organized

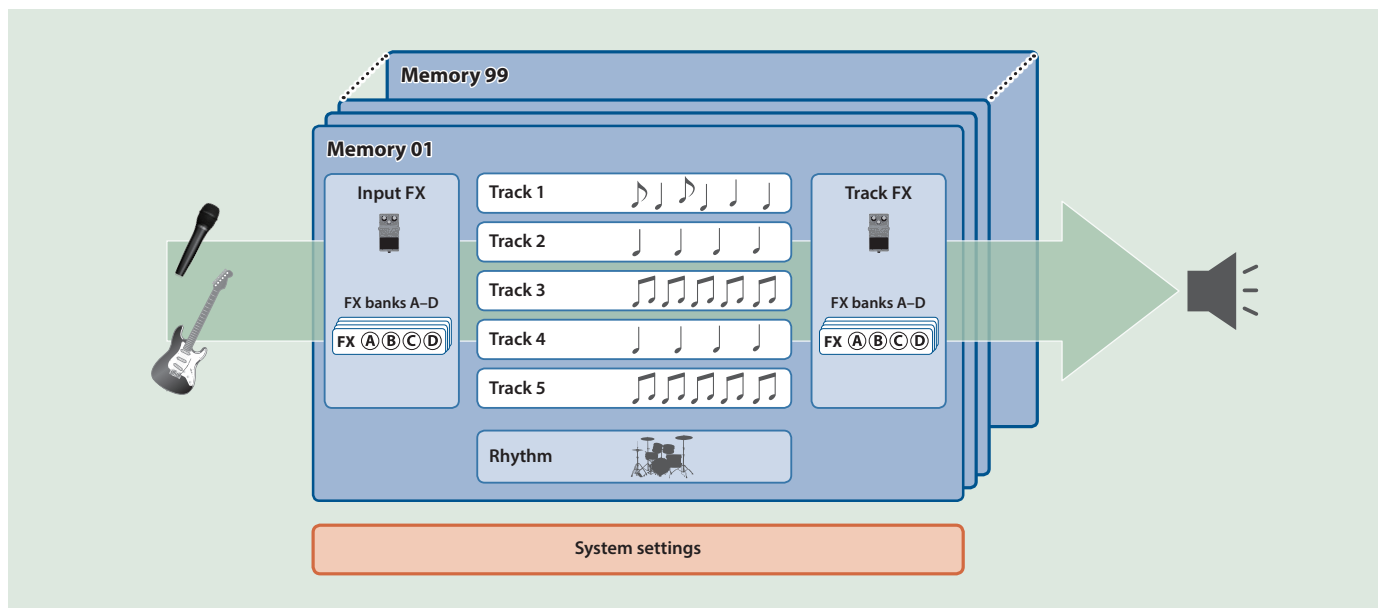

## Track

Tracks are used for recording and playing back audio from a microphone or a musical instrument.

You can combine tracks 1–5 when using this unit.

## Input FX, Track FX

Effects that are applied to the input audio are called “input FX”, and effects that are applied to the tracks are called “track FX”.

You can register 16 input/track FX (4 banks x 4 types) to the buttons and use them.

Use the [INPUT FX]/[TRACK FX] knobs to control the parameters specified for each effect in real time.

## Rhythm

In addition to playing back tracks 1–5, you can also play rhythms with this unit.

You can record while listening to a rhythm at the tempo you specify.

## Memory

The settings for tracks 1–5 together with the input FX/track FX and rhythm are collectively called a “memory”.

You can store up to 99 memories with this unit.

## System settings

Settings that are common to the RC-505mkII overall such as the display contrast, USB and MIDI settings are called “system settings”.

### “Recording” versus “Overdubbing”

In this manual, we refer to the act of recording to an empty track for the first time as “recording”. Any subsequent recordings that are made, which are added on top of the existing recording, we refer to as “overdubbing”.

# Getting Ready

## Top Panel



### 1 INPUT FX

#### [INPUT FX] knob

This knob controls the input FX parameters. The parameters available for control depend on the type of effect selected.

#### [A]–[D] buttons

These buttons turn the effects on/off that are set for each button.

Lit red	Effect: on
Lit pink	Indicates the effect you can currently operate/edit (effect: on).
Unlit	Effect: off

When these control the FX bank switching function, the buttons switch between FX banks A–D.

#### [EDIT] button

Press	Displays the edit screen for the currently selected effect.
Hold this button down, and press the [A]–[D] buttons	Displays the edit screen for the effect that is set for the button you press ([A]–[D]).
Press and hold	The [A]–[D] buttons now switch between FX banks.
	The button ([A]–[D]) for the currently selected FX bank lights up blue.

### 2

#### [ALL START/STOP] button

This makes all tracks start (play back) at the same time. If you press this button when the tracks are currently playing back or recording, all tracks stop.

#### MEMO

You can set which tracks to start at the same time for each memory.

#### [UNDO/REDO] button

Turns the undo/redo function on and off. When this is on (the button is lit), you can use the buttons for tracks 1–5 for undo and redo.

➔ “MARK BACK function” (p. 5)

### 3

#### [MENU] button

This button gives you access to the overall system settings and USB/MIDI settings of the RC-505mkII.

#### [LOOP] button

Press this button to edit a memory. Use this to configure the settings for tracks 1–5, settings related to loop playback/recording and so on, input FX/track FX settings, rhythm settings and the memory name.

#### Display

Shows various information of the RC-505mkII.

#### [EXIT] button

Press to return to the previous screen.

#### [ENTER] button

Press to confirm an operation.

- If you press the [ENTER] button while the play screen is shown, the screen switches to the MIXER screen (p. 8).
- By pressing the [EXIT] button and [ENTER] button simultaneously, you can save a memory (write) or erase (clear) memory data.

#### [◀] [▶] buttons

Use these buttons to move the cursor and switch between pages. If you press these buttons while the play screen is shown, you can switch between variations of the play screen.

#### [1]–[4] knobs

Use these knobs to set the parameter values shown in the screen.



- To change a value in larger steps, turn a knob while pressing it.
- For some parameters, you must press the knob to edit the value.

#### [OUTPUT LEVEL] knob

Adjusts the volume of the RC-505mkII.

4

**[TAP TEMPO] button**

Set the tempo by pressing this button at the desired interval (tap tempo). When doing this, the tempo is shown on the screen. Long-press the button to return to the previous tempo.

5 RHYTHM

**RHYTHM [EDIT] button**

Press this to edit the rhythm settings.

**RHYTHM [START/STOP] button**

The rhythm switches between start/stop each time you press this button.

6 TRACK FX

**[TRACK FX] knob**

This knob controls the track FX parameters. The parameters available for control depend on the type of effect selected.

**[A]–[D] buttons**

These buttons turn the effects on/off that are set for each button.

Lit red	Effect: on
Lit pink	Indicates the effect you can currently operate/edit (effect: on).
Unlit	Effect: off

When these control the FX bank switching function, the buttons switch between FX banks A–D.

**[EDIT] button**

Press	Displays the edit screen for the currently selected effect.
Hold this button down, and press the [A]–[D] buttons	Displays the edit screen for the effect that is set for the button you press ([A]–[D]).
Press and hold	The [A]–[D] buttons now switch between FX banks.
	The button ([A]–[D]) for the currently selected FX bank lights up blue.

**MARK BACK function**

This function lets you undo or redo a certain phrase you recorded as an overdub.

When you use this to memorize (mark) a phrase beforehand that you recorded as an overdub, you can restore a marked phrase to a previously overdubbed state, correct what you played by playing it again or undo/redo the marked phrase to add emphasis to what you played, even after overdubbing several times.

7 TRACK 1–5

**[FX] buttons**

These buttons select whether to apply track FX for each track or not (effects are applied when the buttons are lit, and not applied when unlit).

**[TRACK] button**

Press these buttons to configure a track's settings. These also indicate each track's status.

Lit	Phrase exists
Unlit	No phrase

**MEMO**

The track that is currently selected (currently the target of operations) is called the "current track".

**[■] button**

Press to stop recording, playback, and overdubbing. If you long-press the button (two seconds or longer), the track is cleared.

**[▶/●] button**

Switches between recording, playback, and overdubbing.

**For an empty phrase:**

Recording → Playback → Overdubbing

**For a phrase that contains data:**

Playback → Overdubbing

During recording/playback/overdubbing, the color of the button changes according to the status.

Lit red	Recording
Lit green	Playing
Lit yellow	Overdubbing
Unlit	Stopping

**Loop indicators**

Indicates the track's status, loop position and playback level.

**Track sliders**

These adjust the volume on each track.

**When the [UNDO/REDO] button is lit**

The functions of the buttons from the [FX] button to the [▶/●] button change as shown below.

Button	Function	Explanation
[FX]	MARK CLEAR	Deletes a mark that has been set.
[TRACK]	MARK SET	Sets a mark for an overdubbed phrase.
[■]	MARK BACK	Switches the undo/redo target to the phrase for which a mark has been set. If a mark has not been set, the track switches to the post-recording state.
[▶/●]	UNDO/REDO	Undoes or redoes the recording or overdub you just made.

## Rear Panel (Connecting Your Equipment)

To prevent malfunction and equipment failure, always turn down the volume, and turn off all the units before making any connections.

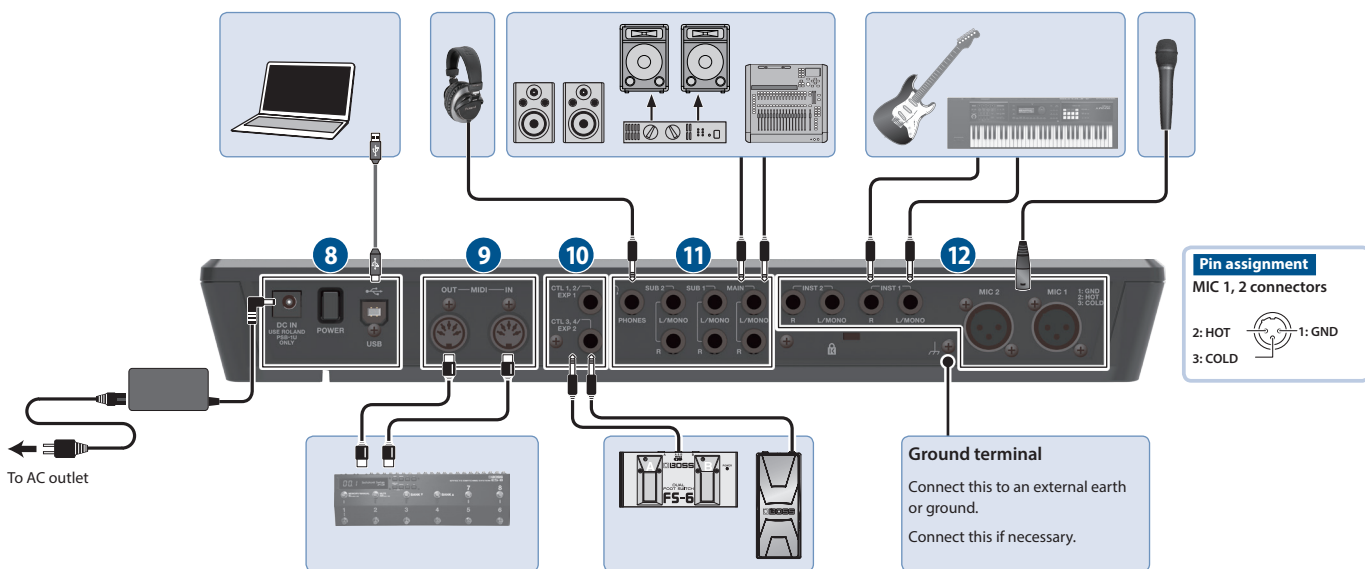

### 8 DC IN jack

Connect the included AC adaptor to this jack.

- \* Use only the specified AC adaptor (PSB-1U), connected to an AC outlet of the correct voltage.
- \* Route the cord of the AC adaptor through the grooves on the bottom of the unit as shown in the illustration, to keep it in place.
- \* When turning the unit over, be careful so as to protect the buttons and knobs from damage. Also, handle the unit carefully; do not drop it.



**[POWER] switch**  
Turns the power on/off.

**USB port**  
Connect your computer using a commercially available USB cable that supports USB 2.0.  
You can connect your computer here and use it to back up or recover data.  
You can also use USB audio to play the sound from your computer through this unit, and use USB MIDI to synchronize the tempo of this unit with the DAW software on your computer.

### 9 MIDI

**MIDI OUT, MIDI IN connectors**  
Connect an external MIDI device here.  
This lets you control an external MIDI device from this unit via MIDI.

### 10 CTL/EXP

**CTL 1, 2/EXP 1 jack and CTL 3, 4/EXP 2 jack**

You can connect an expression pedal or footswitches (sold separately) to these jacks, for controlling a variety of functions.

- \* Use only the specified expression pedal (FV-500H, FV-500L, EV-30, and Roland EV-5; sold separately). By connecting any other expression pedals, you risk causing malfunction and/or damage to the unit.

### 11 OUTPUT

**MAIN jacks (L/MONO, R)**  
**SUB 1, 2 jacks (L/MONO, R)**  
Connect these jacks to your amp, monitor speakers or mixer.

**MEMO**  
You can set the MAIN/SUB jacks as parallel output jacks (mono output x 6) that individually output the sounds from each track.  
➔ "Parameter Guide" (PDF)

**PHONES jack**  
Connect your headphones here.

**MEMO**  
You can configure this unit to let you listen to only the audio you specify in headphones.  
➔ "Parameter Guide" (PDF)

### 12 INPUT

**INST 1, 2 jacks (L/MONO, R)**  
Connect your guitar/bass, effect units, keyboards and other instruments to these jacks.

**MIC 1, 2 connectors**  
Connect your microphone(s) here.

- \* If you're using a condenser mic that requires phantom power, turn on this unit's phantom power (p. 7).

## Connecting footswitches

Connect one or more footswitches and set their mode/polarity switches by referring to the illustrations below.

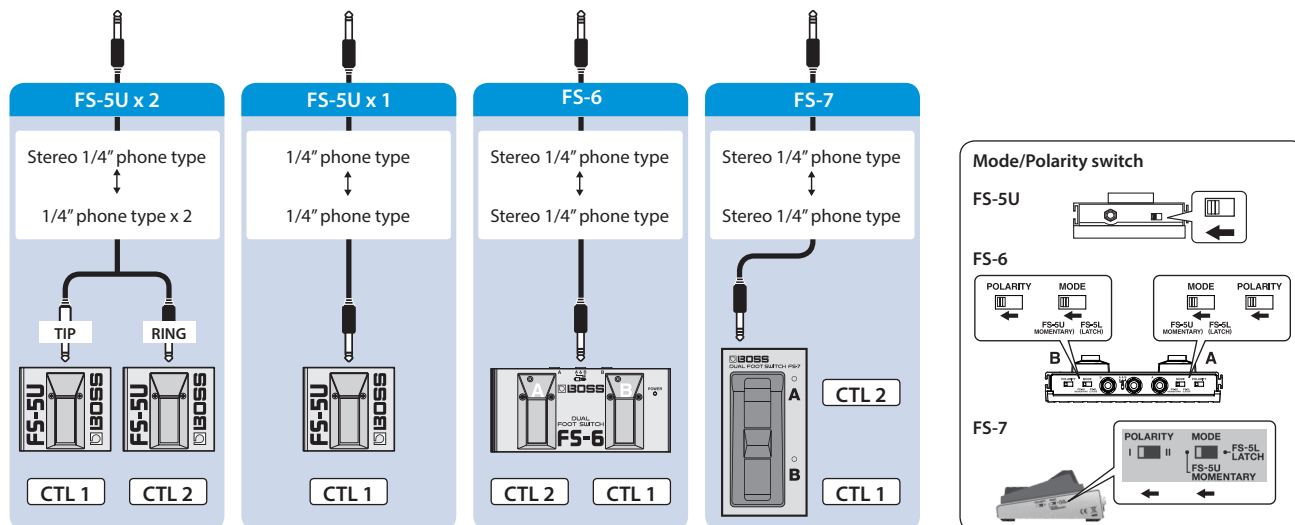

## Turning the Power On/Off

Before turning the unit on/off, always be sure to turn the volume down. Even with the volume turned down, you might hear some sound when switching the unit on/off. However, this is normal and does not indicate a malfunction.

### Turning the Power On

Turn on the power in the following order: this unit ([POWER] switch: ON) → connected devices → amplifier.

### Turning the Power Off

Turn off the power in the following order: amplifier 0 connected devices 0 this unit ([POWER] switch: OFF).

The power to this unit will be turned off automatically after a predetermined amount of time has passed since it was last used for playing music, or its buttons or controls were operated (AUTO OFF function).

If you do not want the power to be turned off automatically, disengage the AUTO OFF function (p. 18).

- Unsaved data is lost when the power turns off. Before turning the power off, save the data that you want to keep (p. 12).
- To restore power, turn the power on again.

## Phantom Power Settings

If you're using a condenser mic that requires phantom power, use the settings below to turn on this unit's phantom power.

1. Press the [MENU] button.



2. Press the [1] (INPUT) knob.



3. Press the [1] (SETUP) knob.



4. Turn the [1] (MIC1)/[2] (MIC2) knobs to set PHANTOM to "ON".
5. Press the [EXIT] button to return to the play screen (p. 8).

### NOTE

Always turn the phantom power off when connecting any device other than condenser microphones that require phantom power.

## Switching Between Play Screens

The screen that appears after you turn on the power is called the “play screen”.

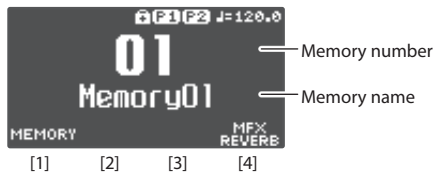

Icon	Explanation
J=120.0	Tempo
[P1][P2]	Phantom power for MIC 1, 2 connectors is on (off when not displayed)
[+]	Knob lock function is on (off when not displayed)

Parameters to set using the [1]–[4] knobs

Press the [◀] or [▶] button while the play screen is shown to switch between variations of the play screen.

### (1) MEMORY NUMBER



### (2) TRACK STATUS

Loop track status is shown with an icon



Icon	Explanation
[Square]	Recording, playing back, overdubbing
[Square with bar]	Stopped (phrase exists)
[Square with bar and dot]	No phrase
[Square with bar and dot in center]	Current track

### (3) LOOP TRACKS

Displays the track status + progress during playback



### (4) LOOP STATUS

Indicates the status of the tracks



### (5) LOOP LEVEL

Volume of each track is shown by the level meters

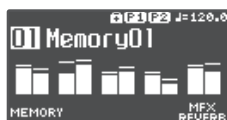

### (6) INPUT FX

Indicates the input FX status

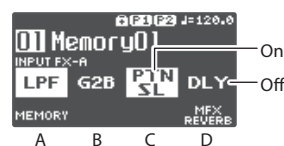

### (7) TRACK FX

Indicates the track FX status



\* You can change which play screen is shown on startup.

➔ “Parameter Guide” (PDF)

## Adjusting the Input/Output Level

Press the [ENTER] button while the play screen is shown to display the MIXER screen, where you can check the input/output levels for each jack and connector.

Use the [◀] [▶] buttons to switch between pages, and turn the [1]–[4] knobs to adjust the respective input/output levels.

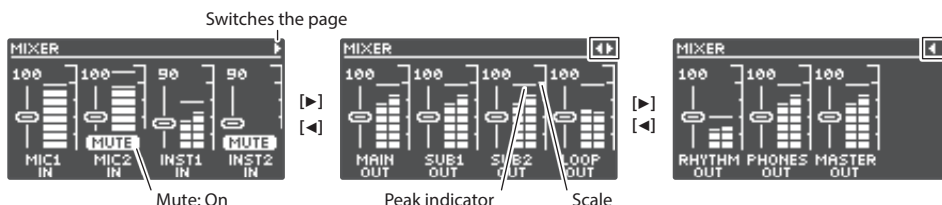

- Adjust the levels so that the peak indicator on the level meter matches the scale shown in the illustration.
- For the inputs, push the [1]–[4] knobs to mute the sound.
- Use the “MASTER OUT” to adjust the levels of the MAIN OUTPUT, SUB 1 OUTPUT and SUB 2 OUTPUT. The [OUTPUT LEVEL] knob is configured to adjust the levels as well by factory default.

The jacks and connectors shown in the MIXER screen may change, depending on the stereo link settings.

Stereo link	Explanation
ON	The MIC 1, 2 and L/R channels are shown as a single connector.
OFF	The MIC 1, 2 and L/R channels are shown separately.

\* For details on stereo link, refer to the “Parameter Guide” (PDF).



# Creating a Loop Phrase

## Recording on a Single Track

Here's how to record and overdub on track 1.

### Getting ready to record

1. Connect your microphones and instruments.
2. Adjusts the input/output level (p. 8).
3. Use the [OUTPUT LEVEL] knob to adjust the overall volume of the RC-505mkII.



4. On the play screen, turn the [1] (MEMORY) knob to select a memory.



Lit	Phrase exists
Unlit	No phrase

5. Use the track slider to adjust the volume for the playback track.



### Undo/Redo

1. Press the [UNDO/REDO] button to make it light.

[▶/●] button	Explanation
Lit green	Undo available
Lit red	Redo available
Unlit	Undo/redo not available



## Recording on Multiple Tracks

You can use multiple tracks to create a single loop phrase.  
 This shows you how to record the tracks in ascending order (track 1 → track 2 → ... track 5).

**Track 1 Recording**



1. Press the [▶/●] button to start recording. The [▶/●] button lights red.
2. Sing/speak into your mic or play your instrument to input audio.



**Track 1 Playback**

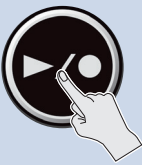

1. Press the [▶/●] button. The [▶/●] button lights green. The recorded phrase plays as a loop.

Repeat as many times as necessary.

**Track 1 Overdubbing**



1. Press the [▶/●] button to start overdubbing. The [▶/●] button lights yellow.
2. Record by overdubbing the audio (your performance) onto the phrase that's playing back in a loop.

:

**Track 1 Playback**

Press the [▶/●] button.



**Track 2 Recording**



1. Press the [▶/●] button to start recording. The [▶/●] button lights red.
2. Sing/speak into your mic or play your instrument to input audio.



**Track 2 Playback**



1. Press the [▶/●] button. The [▶/●] button lights green. The recorded phrase plays as a loop.



**Track 2 Overdubbing**

Repeat as many times as necessary.

**Track 2 Playback**

Press the [▶/●] button.



**Tracks 3–5**

As with track 2, record/playback/overdub tracks 3 → 4 → 5 in ascending order.

:

**Stopping**



1. Press the [ALL START/STOP] button. The [ALL START/STOP] button and the [▶/●] buttons for each track go dark. If you want to keep the recorded phrase, save it in a memory (p. 12).

## Undo/Redo

1. Press the [UNDO/REDO] button to make it light.

[▶/●] button	Explanation
Lit green	Undo available
Lit red	Redo available
Unlit	Undo/redo not available

2. Press the [▶/●] button of the track you want to undo/redo.

3. Press the [UNDO/REDO] button once more to return to the previous state.

## Recording with Input FX

You can apply input FX to the input sound as you record.



1. Press the [FX] button for each track to turn its effects (input FX/track FX) on/off.

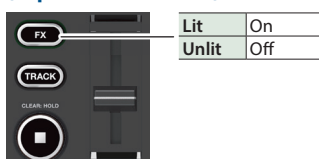

2. Press the INPUT FX [A]–[D] buttons to select the input FX type.



### Switching between FX banks

1. Hold down the [EDIT] button until one of the [A]–[D] buttons lights up blue.  
The [A]–[D] buttons now switch between FX banks.
2. Press the [A]–[D] buttons to switch the FX bank.
3. When you've set the FX bank, press the [EDIT] button.
3. Turn the [INPUT FX] knob to control the effect.  
The parameters available for control depend on the type of effect selected.
4. To apply track FX to a tracks that's already recorded, use the same operation as with the input FX.



- You can save the effects you configured as settings in memory.  
➔ "Saving a Memory (WRITE)" (p. 12)
- You can switch between effect types that are assigned to the [A]–[D] buttons, and change how the effects sound.  
➔ "Editing the Input FX/Track FX Settings" (p. 16)

## Record While Listening to the Rhythm Sound

In addition to the track, the RC-505mkII can also play a "Rhythm". You can record while sounding a rhythm at the tempo you specify.



### Sounding a Rhythm

1. Press the RHYTHM [START/STOP] button.  
The rhythm switches on (lit)/off (unlit)/ready to play rhythm (blink) each time you press the button.

### Setting the Tempo of Rhythm

1. Press the [TAP TEMPO] button.  
The tempo setting screen appears.



2. While the tempo setting screen is shown, turn the [4] knob to set the tempo.

Value 40.0–300.0

#### MEMO

Press and then turn the [4] knob to set a value in decimal points.

### Tap tempo

You can set the tempo by pressing a button at the desired interval.

1. Press the [TAP TEMPO] button several times in time with the desired tempo.

#### MEMO

If you long-press the [TAP TEMPO] button until it begins blinking red, the tempo returns to the default value.

- The specified tempo can be saved as a setting in memory.  
➔ "Saving a Memory (WRITE)" (p. 12)
- You can specify the volume and type (variation) of rhythm, and how the rhythm plays.  
➔ "Editing the Rhythm Settings" (p. 15)

# Saving a Memory

## Saving a Memory (WRITE)

If you select a different memory or turn off the power after recording or editing the settings, the recorded content or edited settings are lost. If you want to keep the data, you must save it.



1. Press the [EXIT] button and [ENTER] button simultaneously.

The WRITE screen appears.



2. Press the [1] or [2] (WRITE) knob.



3. Turn the [1]–[4] knobs to select the memory to which you want to save.

- This procedure is not required if the memory number is acceptable as is.
- If you decide to cancel, press the [EXIT] button.

4. Press the [ENTER] button.

The memory is saved.

- \* Make sure not turn to off the power while the “EXECUTING...” message is shown.

### MEMO

You can assign a name to the memory. For details, refer to “Parameter Guide” (PDF).

## Erasing Data from a Memory (CLEAR)

You can erase the data that is saved in a memory, clearing that memory to an empty state.



1. Press the [EXIT] button and [ENTER] button simultaneously.

The WRITE screen appears.



2. Press the [3] or [4] (CLEAR) knob.

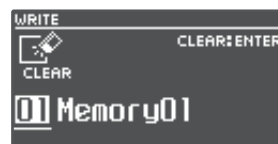

3. Turn the [1]–[4] knobs to select the memory you want to clear.

- This procedure is not required if the memory number is acceptable as is.
- If you decide to cancel, press the [EXIT] button.

4. Press the [ENTER] button.

The memory will be cleared.

- \* Make sure not turn to off the power while the “EXECUTING...” message is shown.

# Editing a Memory

## Editing the Settings of a Memory

Here's how to edit the settings of each memory.

For details on the parameters, refer to "Parameter Guide" (PDF).



### 1. Press the [LOOP] button.

The LOOP screen appears.



### 2. Use the [◀] [▶] buttons to switch to the page containing the item you want to edit.

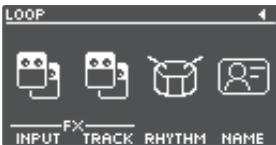

### 3. Press the [1]–[4] knobs to select the parameter to edit.

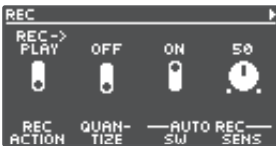

### 4. Use the [◀] [▶] buttons to switch to the page containing the parameter you want to edit.



### 5. Turn the [1]–[4] knobs to edit the values.

### 6. Press the [EXIT] button a number of times to return to the play screen.

### 7. If you want to save the edited settings, execute the Write operation (p. 12).

Item	Explanation
TRACK	Configures tracks 1–5. Turn the [1] knob to select the track to edit.
REC	Configures the settings related to recording/overdubbing.
PLAY	Specifies how loop phrases play back.
INPUT FX	Configures the input FX.
TRACK FX	Configures the track FX.
RHYTHM	Configures the rhythm settings.
NAME	Specifies the memory name. * Maximum of 12 characters

## Editing the Track Settings

Here's how to configure the volume, playback method and other settings for tracks 1–5.

For details on the parameters, refer to "Parameter Guide" (PDF).

\* You can also configure the track parameters from the edit screen of a memory.



1. Press a [TRACK] button (tracks 1–5) to select a track to edit.

The TRACK screen appears.



### MEMO

You can also press the [LOOP] button to switch tracks.

2. Use the [◀] [▶] buttons to switch the page containing the parameter you want to edit.



3. Turn the [1]–[4] knobs to edit the values.
4. Press the [EXIT] button a number of times to return to the play screen.
5. If you want to save the edited settings, execute the Write operation (p. 12).

Item	Explanation	
REVERSE	Specifies whether to play back normally or in reverse.	
1SHOT	Specifies whether to play back as one-shot or as the usual loop playback.	
PAN	Specifies the stereo position (pan) of the track.	
PLAY LEVEL	Adjusts the playback level of the track.	
START MODE	Specifies whether playback starts with a fade-in or immediately when the track plays.	
STOP MODE	Specifies how the track stops.	
DUB MODE	Specifies the overdubbing method.	
FX	Turns the effects (input FX/track FX) on/off. * You can also press the [FX] button of the currently selected track to switch the effect on/off.	
PLAY MODE	Specify how loop phrases play back.	
MEASURE	Specifies the number of measures in the track.	
LOOP SYNC	Specifies whether the phrases played back on tracks 1–5 are lined up at the beginning and then looped, or whether each phrase is looped separately according to their length.	
TEMPO SYNC	SW	Sets whether each track plays at its original tempo (the tempo during recording—use the OFF setting) or at the tempo that is specified in the memory (use the ON setting).
	MODE	When TEMPO SYNC SW is "ON", this sets whether to change the pitch according to the tempo, or to instead make the pitch stay the same.
	SPEED	Sets the playback speed for each track.
BOUNCE IN	Sets whether to allow the playback sound from a different track as well to be recorded during recording or overdubbing.	
INPUT	Sets whether the sound from each input jack/connector and the rhythm should be inputted to the track (ON) or not (OFF). Turn the [1] knob to select the input jack/connector or RHYTHM, and press the [1] knob to switch between ON/OFF. * When stereo link is "ON", the MIC 1, 2 and L/R channels are shown as a single connector.	

## Editing the Rhythm Settings

For details on the parameters, refer to “Parameter Guide” (PDF).

\* Rhythm parameters can also be edited from the edit screens for a memory.



### 1. Press the RHYTHM [EDIT] button.

The RHYTHM screen appears.



### 2. Use the [◀] [▶] buttons to switch between the parameters that you want to edit.



### 3. Turn the [1]–[4] knobs to edit the values.

### 4. Press the [EXIT] button a number of times to return to the play screen.

### 5. If you want to save the edited settings, execute the Write operation (p. 12).

Item	Explanation
GENRE	Selects the genre of the rhythm pattern.
PATTERN	Selects the rhythm pattern.
VARIATION	Selects the rhythm pattern variation.
KIT	Selects the drum kit used to play the rhythm.
BEAT	Specifies the time signature of the rhythm.
START TRIG	Specifies how rhythm playback starts.
STOP TRIG	Specifies how rhythm playback stops.
INTRO REC	Sets whether to add an intro or not when recording.
INTRO PLAY	Specifies whether the rhythm plays with or without an intro.
ENDING	Specifies whether the rhythm plays with or without an ending.
FILL	Specifies whether the rhythm plays with a fill-in or without a fill-in.
VARI. CHANGE	Specifies the timing at which the rhythm pattern's variation is changed.

## Changing How the Rhythm Starts and Stops

As appropriate for your recording method or the phrase that you're recording, you can change the way in which the rhythm starts and stops.

### 1. From the RHYTHM screen, switch to the page on which “START TRIG” is shown.



### 2. Turn the [2] (START TRIG) knob to set the rhythm playback method.

### 3. Turn the [3] (STOP TRIG) knob to set the rhythm stop method.

### 4. Press the [EXIT] button a number of times to return to the play screen.

### 5. If you want to save the edited settings, execute the Write operation (p. 12).

Parameter	Explanation
<b>START TRIG</b>	
LOOP START	The rhythm plays when loop recording or playback starts.
REC END	The rhythm plays when loop recording ends and switches to playback. This is useful if you want to perform without specifying a tempo, start recording and then play the loop in time with the rhythm when playback starts.
BEFORE LOOP	The rhythm plays before loop recording or playback. The rhythm starts playing when you press the switch once, and recording/playback starts in time with the rhythm when you press the switch once again.
<b>STOP TRIG</b>	
OFF	The rhythm always continues playing. If you are performing in synchronization with an external MIDI device, you can keep the rhythm playing continuously to allow synchronized playback.
LOOP STOP	The rhythm stops when the loop stops.
REC END	The rhythm stops when loop recording ends. This is useful when you want to use the rhythm as a guide during recording.

### Editing the Input FX/Track FX Settings

For details on the parameters, refer to “Parameter Guide” (PDF).



1. Select the memory for which you want to edit the input FX/track FX settings.
2. Press the INPUT FX [EDIT] button/TRACK FX [EDIT] button.

The INPUT FX screen/TRACK FX screen appears.



3. Select the FX bank of the effect you wish to edit.
  1. Hold down the [EDIT] button until one of the [A]–[D] buttons lights up blue.  
The [A]–[D] buttons now switch between FX banks.
  2. Press the [A]–[D] buttons to switch the FX bank.
  3. When you've set the FX bank, press the [EDIT] button.
4. Press the [A]–[D] buttons while holding down the [EDIT] button to select the effect to edit.
5. Use the [◀] [▶] buttons to switch to the page containing the parameter you want to edit.  
\* The available parameters depend on the type of effect you select.
6. Turn the [1]–[4] knobs to edit the values.
7. Press the [EXIT] button a number of times to return to the play screen.
8. If you want to save the edited settings, execute the Write operation (p. 12).



# System Settings (MENU)

For details on the parameters, refer to “Parameter Guide” (PDF).



## 1. Press the [MENU] button.

The MENU screen appears.



## 2. Use the [◀] [▶] buttons to switch to the page containing the item you want to edit.



## 3. Press the [1]–[4] knobs to select the item that you want to edit.



## 4. If you see another screen with items to select, repeat steps 2 and 3.

## 5. Use the [◀] [▶] buttons to switch to the page containing the parameter you want to edit.



## 6. Turn the [1]–[4] knobs to change the value.

## 7. Press the [EXIT] button a number of times to return to the play screen.

Item	Parameter/Explanation
INPUT	<b>SETUP</b> Settings related to the input and output jacks, such as phantom power on/off.
	<b>EQ</b> Settings for applying an equalizer effect to the input sound for each connector/jack.
	<b>DYNAMICS</b> Settings for applying a compressor or noise suppressor to the input sound.
OUTPUT	<b>SETUP</b> Settings related to the output jacks, such as stereo link.
	<b>ROUTING</b> Settings for assigning the playback sound from tracks 1–5 and the input/rhythm sound from each input jack/connector to the output jacks.
	<b>EQ</b> Settings for applying an equalizer effect to the output sound, configured for each output jack.
	<b>MASTER FX</b> Settings for the compressor and reverb effects that are applied to the output sound.
MIXER	Sets the input/output levels for each jack and connector (p. 8).
CTL FUNC	<b>PANEL PLAY, PANEL UNDO</b> Settings for the [TRACK] button/[FX] buttons (tracks 1–5), for the [TRACK] button during undo/redo, and for the [FX] button functions.
	<b>CTL/EXP</b> Settings for assigning functions to a footswitch or expression pedal connected to the CTL 1, 2/EXP 1 jack or the CTL 3, 4/EXP 2 jack.
	<b>PREFERENCE</b> Selects whether to switch the PANEL PLAY, PANEL UNDO, and CTL/EXP settings to either the settings for each memory or to the system settings. * When switching to the settings for each memory, use the write operation to save the settings to memory.
ASSIGN	<b>ASSIGN 1–16</b> Settings for the ASSIGN section. By using the assign settings, you can control other parameters at the same time as the specified functions that are executed when you operate this unit's buttons/knobs, or a footswitch/expression pedal connected to the CTL 1, 2/EXP 1 jack or CTL 3, 4/EXP 2 jack. You can also configure this unit to be controlled from an external MIDI device. There are 16 different assign settings.

English

日本語

Deutsch

Français

Italiano

Español

Português

Nederlands

## System Settings (MENU)

Item	Parameter/Explanation
USB	<b>STORAGE</b>
	Settings for how USB should operate.
	<b>AUDIO MODE</b>
	Settings for the USB driver when USB audio is used.
	<b>AUDIO ROUTING</b>
	Settings for where the USB audio is routed.
	<b>INPUT LEVEL</b>
	Configures the USB audio input level.
MIDI	<b>OUTPUT LEVEL</b>
	Configures the USB audio output level.
	<b>RX CH CTL</b>
	Specifies the receive channel for messages (control changes) that switch memories or control the RC-505mkII.
	<b>RX CH RHYTHM</b>
	Specifies the receive channel for note messages that play the drum sounds.
	<b>RX CH VOICE</b>
	Specifies the receive channel for note messages used to create harmonies or vocoder effects.
	<b>TX CH</b>
	Specifies the transmit channel for MIDI messages.
	<b>SYNC CLOCK</b>
	Specifies the input to which the tempo clock is synchronized.
	<b>SYNC OUT</b>
	Sets whether to output MIDI clock or not.
	<b>SYNC START</b>
	Specifies what starts in synchronization when a MIDI start message is received.
<b>PC OUT</b>	
Sets whether to transmit program change messages or not.	
<b>THRU MIDI IN</b>	
Specifies the connector used to output the MIDI messages received through the MIDI IN connector.	
<b>THRU USB IN</b>	
Specifies the connector used to output the MIDI messages that are received through the USB port.	
SETUP	<b>CONTRAST</b>
	Adjusts the display contrast.
	<b>DISPLAY MODE</b>
	Sets which play screen is shown on startup.
	<b>INDICATOR</b>
	Settings for what the loop indicator should display.
<b>FX KNOB MODE</b>	
Sets how the [INPUT FX] knob/[TRACK FX] knob operate.	
<b>AUTO OFF</b>	
Turns the AUTO OFF function on/off.	

Item	Parameter/Explanation
SETUP	<b>MEMORY EXT MIN, MAX</b>
	Specifies the extent (lower limit and upper limit) to which memories can be switched.
FACTORY RESET	<b>KNOB FUNC 1-4</b>
	Specifies the functions that are assigned to the [1]–[4] knobs.
	Restores the unit to its factory settings (p. 24).

# Connecting to a Computer via USB

Here's what you can do when you connect the RC-505mkII via USB to your computer.

- Back up the RC-505mkII's data to your computer.
- Restore (recover) backup data from your computer to the RC-505mkII.
- Use BOSS TONE STUDIO to import or back up loop phrases (audio files).
- Use the dedicated rhythm converter if you want to import and use your original rhythm patterns on the RC-505mkII.

## Using BOSS TONE STUDIO and the rhythm converter

Access the website shown below to download BOSS TONE STUDIO or the rhythm converter.

➔ <https://www.boss.info/support/>

## Connecting to your computer

Use a commercially available USB cable to connect the RC-505mkII's USB port to the USB port on your computer.

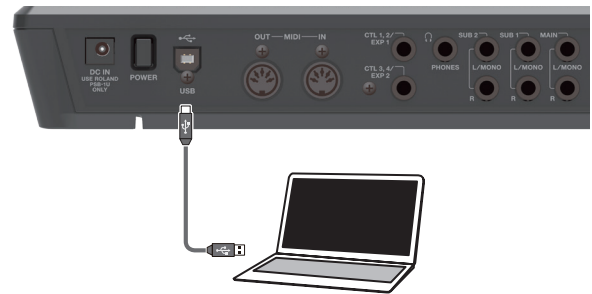

### NOTE

- Use a USB cable that supports USB 2.0 Hi-Speed.
- This might not work correctly for some models of computer. Refer to the BOSS website for details on the operating systems that are supported.

## Backing Up or Recovering Data

### 1. Press the [MENU] button.

The MENU screen appears.



### 2. Use the [◀] [▶] buttons to switch to the page on which "USB" is shown, and press the [2] (USB) knob.



### 3. Turn the [1] (STORAGE) knob to set "PREPARING...".

### 4. Use a USB cable to connect the RC-505mkII's USB port to your computer's USB port.

When a connection with the computer is established, the message "CONNECTING..." appears.

\* USB connection is not possible if the unit is not stopped, or if there is a phrase that has not been saved.

### 5. Open the BOSS RC-505mkII drive.

#### Windows

Within My Computer (or Computer), open "BOSS RC-505mkII" (or Removable Disk).

#### macOS

On the desktop, open the "BOSS RC-505mkII" icon.

### 6. Back-up or recover the data.

#### Backup

Copy the entire "ROLAND" folder from the BOSS RC-505mkII drive to your computer.

#### Recover

\* When you execute this operation, the memory currently saved in the RC-505mkII disappears. Back up in advance.

In the BOSS RC-505mkII drive, delete the "ROLAND" folder, and then copy the backed-up "ROLAND" folder from the computer into the BOSS RC-505mkII drive.

### NOTE

Do not delete the folders in the BOSS RC-505mkII drive other than when executing the recovery operation.

### 7. Eject the BOSS RC-505mkII drive.

#### Windows

In the lower right of your screen, click the [🔌] and then the [🗑️] icon, and then click "Eject BOSS RC-505mkII".

#### macOS

Drag the "BOSS RC-505mkII" icon to the trash ("Eject" icon).

# Controlling Devices via MIDI

## Connection

Connect external MIDI devices to this unit according to your needs.

Connector	Explanation
MIDI IN	Receives messages from another MIDI device.
MIDI OUT	Transmits messages from this device.

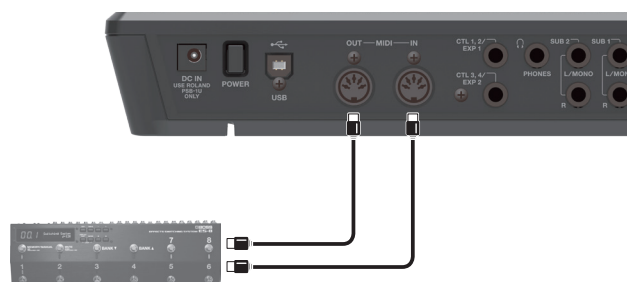

## MIDI Settings

Use of MIDI requires that the MIDI channels be matched with those of the connected device. Data cannot be transmitted to, nor received from another MIDI device unless the MIDI channels are set properly.

For details on each of the MIDI setting parameters, refer to “Parameter Guide” (PDF).

## Controlling an External MIDI Device from the RC-505mkII

Overview	Explanation
<b>Transmitting tempo data and data for starting and stopping playback</b>	
The RC-505mkII's performance tempo data is transmitted to external MIDI devices as MIDI Clock.	<b>Setting an external MIDI device to the same tempo as the RC-505mkII</b> MIDI Clock messages are output from the RC-505mkII at all times. Set the external MIDI device beforehand so it is ready to receive MIDI Clock and MIDI Start and Stop messages. For details, refer to the owner's manual of your device.
Playback start and stop operations with the RC-505mkII's switches can be transmitted as MIDI Start and Stop messages.	<b>Transmitting Start/Stop</b> A MIDI Start message is transmitted at the moment that recording or playback of the track begins, when tracks had been stopped. This message is also transmitted when an All Start is carried out. A MIDI Stop message is transmitted when tracks have stopped. This is also transmitted when All Stop is carried out. * If you want MIDI synchronized performance to continue even after the track stops, set the RHYTHM parameter STOP TRIG (p. 15) to “OFF”. * Tracks whose 1SHOT setting (p. 14) is “ON” and tracks whose LOOP SYNC setting (p. 14) is “OFF” will not transmit Start/Stop data.
<b>Transmitting Program Change messages</b>	
When a memory is selected with the RC-505mkII, a Program Change message corresponding to the selected memory number is transmitted simultaneously.	<b>Transmitting Program Change messages</b> When memories are switched on the RC-505mkII, a MIDI Program Change message is transmitted to the connected external MIDI device. You can transmit Program Change messages numbered 1 through 99, corresponding to the 99 individual memories 01–99. * Set “PC OUT” (p. 18) to ON beforehand. * Program Change messages 100–128 cannot be transmitted. * Bank Select MIDI messages (Control Change #0, #32) cannot be transmitted.
<b>Transmitting Control Change messages</b>	
Operating information for the RC-505mkII's switches, buttons, knobs, and an external expression pedal or footswitch is transmitted as Control Change messages.	<b>Transmitting Control Change messages</b> If you select a Control Change as the “ASSIGN” (p. 17) target, you can transmit MIDI control change messages by operating the buttons and knobs on the RC-505mkII, or by using an external footswitch or expression pedal (connected to the CTL 1, 2/EXP 1 jack or the CTL 3, 4/EXP 2 jack).

## Controlling the RC-505mkII from an External MIDI Device

Overview	Explanation
<b>Receiving tempo data and data for starting and stopping playback</b>	
The RC-505mkII will synchronize to the tempo of MIDI Clock data from an external MIDI device.	<b>Setting the RC-505mkII to the same tempo as an external MIDI device</b> Make settings on your external MIDI device so that it will transmit MIDI Clock and MIDI Start/Stop data. For details, refer to the owner's manual of your device. Set the RC-505mkII's SYNC CLOCK (p. 18) to "AUTO". * You can't switch the tempo during recording.
Start/stop data will be received from an external MIDI device to play/stop the RC-505mkII.	<b>Receiving MIDI Start</b> When MIDI Start (FA) is received, all tracks will play (All Start).
<b>Switching memories</b>	
The RC-505mkII's memories switch simultaneously upon receipt of corresponding Program Change messages from external MIDI devices.	<b>Switching memories</b> You can switch the RC-505mkII's memories with Program Change messages from external MIDI devices. You can receive Program Change messages numbered 1 through 99, corresponding to the 99 individual memories 01–99. * Program Change messages 100–128 cannot be received. * Even if received, Bank Select MIDI messages (Control Change #0, #32) are disregarded.
<b>Receiving Control Change messages</b>	
The RC-505mkII can be controlled using Control Change messages from external MIDI devices.	<b>Receiving Control Change messages</b> You can use Control Change messages from an external MIDI device to control functions that would be difficult to control using the RC-505mkII's own controllers. In the "ASSIGN" (p. 17) setting, set SOURCE to "MIDI CC#1–#31, CC#64–#95", and select the parameter that you want to control in TARGET.

## Connecting Two RC-505mkII Units

Two RC-505mkII units can be synchronized after connecting them together using a MIDI cable.



- Begin recording on the tracks of the transmitting RC-505mkII.
- When you press the [ALL START/STOP] button on the transmitting RC-505mkII, the receiving RC-505mkII also plays back.
  - \* The receiving RC-505mkII performs an "all start" when tracks start playing back on the transmitting RC-505mkII.
- Tracks for which TEMPO SYNC (p. 14) is ON play at the tempo set in the memory of the transmitting unit.
- Tracks for which LOOP SYNC (p. 14) is ON loop in time with the first-recorded phrase on the transmitting RC-505mkII.

# Appendix

## Troubleshooting

Problem	Items to Check	Action
<b>Problems with sound</b>		
<b>No sound/insufficient volume</b>	Is this unit properly connected to other devices?	Check the connections to other devices (p. 7).
	Is the power to the connected amp or mixer not turned on, or is the volume turned down?	Check the settings for connected devices.
	Is there a short in one of the connection cables?	Try replacing the connection cable.
	Might the level sliders for each track or the [OUTPUT LEVEL] knob have been lowered?	Adjust sliders/knob to their suitable positions.
	Is the input/output level set correctly?	Adjust the input/output levels on the MIXER screen for the input/output jacks and connectors respectively.
	Are the levels for tracks 1–5 set correctly?	Check the "PLAY LEVEL" setting for each track (p. 14). Check whether an external expression pedal or other accessory has been set to adjust the levels (p. 17).
	Are the audio output destinations for tracks 1–5 set correctly?	Check the "ROUTING" settings in OUTPUT on the MENU screen (p. 17).
	Has anything been recorded to the tracks?	Check the [TRACK] button for each track to see whether the track has been recorded. If a track's button is unlit, nothing has been recorded on that track.
<b>No rhythm sound</b>	Is the rhythm volume set correctly?	Check the "RHYTHM OUT" setting on the MIXER screen.
	Is the output destination for the rhythm sound set correctly?	Check the RHYTHM settings in "ROUTING", found in OUTPUT on the MENU screen (p. 17).
<b>Sound is missing from the beginning and end of a recorded track</b>	To prevent noise, a fade-in and a fade-out are applied at the beginning and end of a recording. In some cases, it may sound as if some of the sound has been cut out.	
<b>Unable to hear sounds from devices connected to the MIC 1, 2 connectors/INST 1, 2 jacks</b>	Is the audio output destination set correctly?	Check the MIC 1/MIC 2/INST 1/INST 2 settings in "ROUTING", found in OUTPUT on the MENU screen (p. 17).
<b>Problems with operation</b>		
<b>Cannot switch between memories</b>	Is something other than the play screen appearing in the display?	You cannot switch memories while any screen other than the play screen is displayed. Press the [EXIT] button to return to the play screen.
<b>Recording/overdubbing stops before finishing</b>	Is there enough memory remaining?	If there isn't enough memory, clear any unneeded memories (p. 12) before recording or overdubbing.
	Is LOOP SYNC (p. 14) set to "ON" for the track?	When recording with LOOP SYNC set to "ON", once the end of the longest track is reached, this unit automatically switches to overdubbing.
<b>Playback tempo not changing</b>	Is recording or overdubbing in progress?	You cannot change the tempo of the memory while recording or overdubbing. Change the tempo while the tracks are stopped or playing back.
	Is TEMPO SYNC (p. 14) set to "ON" for the track?	When TEMPO SYNC is not set to "ON" for a track, the playback speed does not change even if the tempo for the memory changes. To match the playback speed to the tempo of the memory, set the track's TEMPO SYNC setting to "ON".
<b>Playback tempo not changing</b>	Is the unit synchronized via MIDI?	If MIDI clocks are being received via the MIDI IN connector or the USB port, the RC-505mkII synchronizes its tempo to the MIDI clocks. If you don't want to synchronize with an external device, set SYNC to "INTERNAL".
<b>MIDI messages not being transmitted/received</b>	Is the external MIDI device properly connected?	Check the connections to the external MIDI device.
	Could there be a short in the MIDI cable?	Try replacing the MIDI cable.
	Are the MIDI channels matched to those of the external MIDI device?	Confirm that both devices are set to the same MIDI channels.
	If transmitting from the RC-505mkII, have you made the necessary transmission settings?	Check the TX CH (transmit channel) setting and the PC OUT (program change message transmit) on/off setting.
<b>Problems with USB</b>		
<b>Unable to communicate with computer</b>	Is the USB cable properly connected?	Check the connection (p. 19).
	(If exchanging files via USB with your computer) Could "STORAGE" be OFF?	Using the procedure shown in "Backing Up or Recovering Data" (p. 19), set STORAGE to "PREPARING...".
	Is a memory now being edited?	USB connection is not possible if there is an unsaved memory. Save the memory (p. 12), and then try the USB connection again.

## Error Message List

Message	Meaning	Action
<b>LOOPER</b>		
DATA DAMAGED	Data may have been damaged.	In the factory reset function (p. 24), choose "SYS+MEM" to return the RC-505mkII to its factory settings.
DATA READ ERR	A problem has occurred with the content of the RC-505mkII's memory.	Consult your dealer, a Roland service center, or an official Roland dealer.
DATA WRITE ERR		
DATA TOO LONG	Playback is not possible because the recording time or audio file is too long.	The recording time or audio file length must not exceed 1.5 hours.
DATA TOO SHORT	Playback is not possible because the recording time or audio file is too short.	The recording time or audio file length must be at least 0.1 seconds.
EVENT FULL	Further overdubbing is not possible.	Save the memory (p. 12).
MEMORY FULL	The recorded time of one track exceeded 1.5 hours (approximately). No further recording is possible on the current track.	Save the memory (p. 12). If you want to continue recording, select a different memory.
	The total recording time of all memories exceeded 13 hours (approximately). No further recording is possible.	Clear unneeded memories (p. 12).
NOT EMPTY	You are attempting to overwrite-save onto a memory in which a phrase is already recorded.	Either clear the currently selected memory (p. 12), or select an empty memory.
TEMPO TOO FAST	Since the track is being played at a much faster tempo than when it was recorded, it might not play back correctly.	Adjust the tempo.
TEMPO TOO SLOW	Since the track is being played at a much slower tempo than when it was recorded, it might not play back correctly.	
TOO BUSY	The RC-505mkII could not process the data completely.	Lower the performance tempo.
TOO BUSY OMSG	For "TOO BUSY OMSG": Since you attempted to apply the loop FX to a phrase that was set to a significantly slower tempo than when it was recorded, the data could not be processed quickly enough.	In the case of "TOO BUSY OMSG", return to the tempo that was used during recording.
		Save the current content to a memory.
		If this appears frequently, back up the data to your computer, then execute factory reset "SYS+MEM", and then recover the data (p. 24, p. 19).
UNDEFINED ERR	An error of unknown cause has occurred during recording, playback, or overdubbing.	Consult your dealer, a Roland service center, or an official Roland dealer.
<b>MIDI</b>		
BUFFER FULL	An excessive volume of messages were received and could not be processed properly.	Reduce the number or size of MIDI messages transmitted to the RC-505mkII.
OFFLINE	There is a problem with the MIDI cable connection.	Check to make sure the cable has not been disconnected and that there is no short in the cable.
<b>Others</b>		
MEMORY FULL	This unit's memory is insufficient. If this message appears, recording or overdubbing might end mid-way.	Clear unneeded memories (p. 12), and then try recording again.
STOP LOOPER	The operation is not possible during recording, playback, or overdubbing.	Stop before performing the operation.
STOP ALL	The operation is not possible during recording, playback, overdubbing, or rhythm playback.	Stop all of these before performing the operation.
STOP ALL&SAVE	The operation is not possible during recording, playback, overdubbing, or rhythm playback when there is also unsaved data.	Stop all of these, and then save the memory (p. 12).
UNSUPPORTED FILE	This audio file is unplayable.	Check the format of the audio file.
		To import an audio file into the RC-505mkII, use BOSS TONE STUDIO.

English

日本語

Deutsch

Français

Italiano

Español

Português

Nederlands

## Restoring the Factory Default Settings (Factory Reset)

You can restore all of the settings to their factory-set values, and you can also specify certain items to be reset.

\* When you execute "Factory Reset", the settings you made are lost. Back up any necessary data to your computer.

**1. Press the [MENU] button.**

The MENU screen appears.



**2. Use the [◀] [▶] buttons to switch to the page on which "FACTORY RESET" is shown, and press the [4] (FACTORY RESET) knob.**



**3. Turn the [1]–[4] knobs to select the setting that you want to restore.**

Value	Explanation
MEMORY	Memory 01–99
SYSTEM	System settings
MEMORY+SYSTEM	Memory 01–99 and system settings

\* If you decide to cancel, press the [EXIT] button.

**4. Press the [ENTER] button.**

The factory reset is executed.

\* Make sure not turn to off the power while the "EXECUTING..." message is shown.

Once the factory reset is complete, you are returned to the Play screen.



## Main Specifications

Sampling Frequency	44.1 kHz
AD/DA Conversion	32 bits
Processing	32-bit floating point
Recording/Playback	Number of Tracks: 5 Data Format: WAV (44.1 kHz, 32-bit float, stereo) Maximum Recording Time: Approx. 1.5 hours (1 track), Approx.13 hours (total of All memories)
Rhythm Type	200 types or greater
Rhythm Kit	16 types
Effect	INPUT FX: 49 types TRACK FX: 53 types MASTER FX: 2 types
Memory	99
Nominal Input Level	MIC 1, 2 INPUT: -40 dBu INST 1, 2 INPUT: -10 dBu
Maximum Input Level	MIC 1, 2 INPUT: 0 dBu INST 1, 2 INPUT: +7 dBu/+20 dBu (selectable)
Input Impedance	MIC 1, 2 INPUT: 3 kΩ INST 1, 2 INPUT: 1 MΩ/25 kΩ (selectable)
Nominal Output Level	MAIN OUTPUT: -10 dBu SUB 1, 2 OUTPUT: -10 dBu
Maximum Output Level	MAIN OUTPUT: +7 dBu SUB 1, 2 OUTPUT: +7 dBu
Output Impedance	MAIN OUTPUT: 1 kΩ SUB 1, 2 OUTPUT: 1 kΩ
Recommended Load Impedance	MAIN OUTPUT: 10 kΩ or greater SUB 1, 2 OUTPUT: 10 kΩ or greater
Display	Graphic LCD (128 x 64 dots, backlit LCD)
Connectors	MIC 1, 2 INPUT connectors: XLR type (balanced, phantom power: DC 48 V, 10 mA Max) INST 1, 2 INPUT jacks, MAIN OUTPUT jacks, SUB 1, 2 OUTPUT jacks: 1/4-inch phone type PHONES OUTPUT jack: Stereo 1/4-inch phone type CTL1,2/EXP1 jack, CTL3,4/EXP2 jack: 1/4-inch TRS phone type USB port: USB B type MIDI (IN, OUT) connectors DC IN jack
Power Supply	AC adaptor
Current Draw	1.0 A (with phantom power) 0.9 A (without phantom power)
Dimensions	420 (W) x 234 (D) x 67 (H) mm 16-9/16 (W) x 9-1/4 (D) x 2-11/16 (H) inches
Weight	1.8 kg 4 lbs
Accessories	AC adaptor Owner's Manual Leaflet "USING THE UNIT SAFELY"
Options (sold separately)	Footswitch: FS-5U Dual Footswitch: FS-6, FS-7 Expression Pedal: FV-500H, FV-500L, EV-30, Roland EV-5

\* 0 dBu = 0.775 Vrms

\* This document explains the specifications of the product at the time that the document was issued. For the latest information, refer to the Roland website.

English

日本語

Deutsch

Français

Italiano

Español

Português

Nederlands

 **BOSS**